

## HIGH BAY LIGHT SERIES KUFO

- ◆ S1 UFO high bay light series from 50W-200W. Classic outlook with excellent system efficiency up to 160lm/w. Patented heat dissipation design with lower weight.
- ◆ Super energy saving. 150W can replace 400W HID. Smart control with 0-10V, PWM, Microwave Motion Sensor.

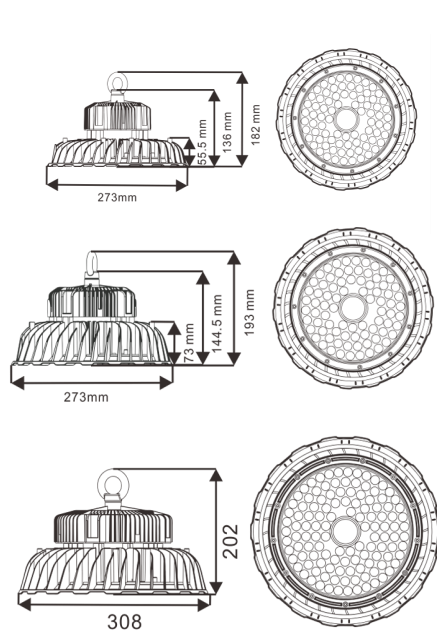

Parameter	Value					
Model	KHBUFO50W	KHBUFO80W	KHBUFO100W	KHBUFO120W	KHBUFO150W	KHBUFO200W
Rate Power	50W	80W	100W	120W	150W	200W
Luminous Flux	8,500lm	13,600lm	17,000lm	20,400lm	22,500lm	34,000lm
Luminous Efficiency	170lm/w					
Color Temperature	CCT 3000K / 4000K / 5000K / 6000K					
Color Rendering Index	>70 Ra					
Input Voltage	AC 100-277 V , 50/60Hz					
Power factor	≥ 0.95					
Beam Angle	60° / 90° / 120°					
Work Temperature	-40°C to 85°C					
Work Life	>50,000 Hours					
IP Rating	IP65					
Net Weight	2.5 Kg		3.3 Kg		3.6 Kg	
Dimensions	273*182 mm		273*192.5 mm		308*202 mm	

## Smart Control

Ready for smart system. 0-10V. PWM , Microwave motion

## Lens

Accurate engineered lens made of optical grade polycar-

## LED Chip

Use customized chip from TOP 5 LED chip manufacturer, Delivering, high luminous efficiency up to 200lm/w.

## Heat Sink

Aluminum alloy Heat sink with powder spraying process. Anti-corrosion, no toxicity or pollution

## Application

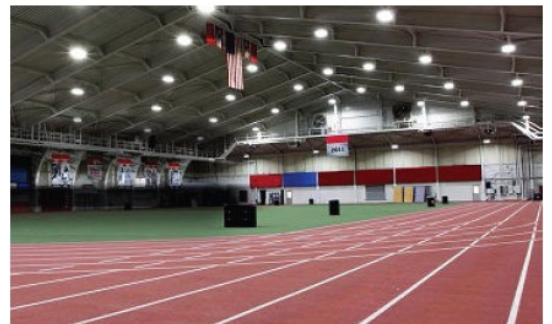

## Light Distribution Curve

